



DUCTLESS

FUME
HOOD



CONTENTS

Ductless Hood Features	3
Ductless Fume Handling	4
Ductless Fume Hood -Models	5
Activated Charcoal Filter & Accessories	6
Parts	7
Options and Accessories	8
Warranty	9

Ductless Hood Features

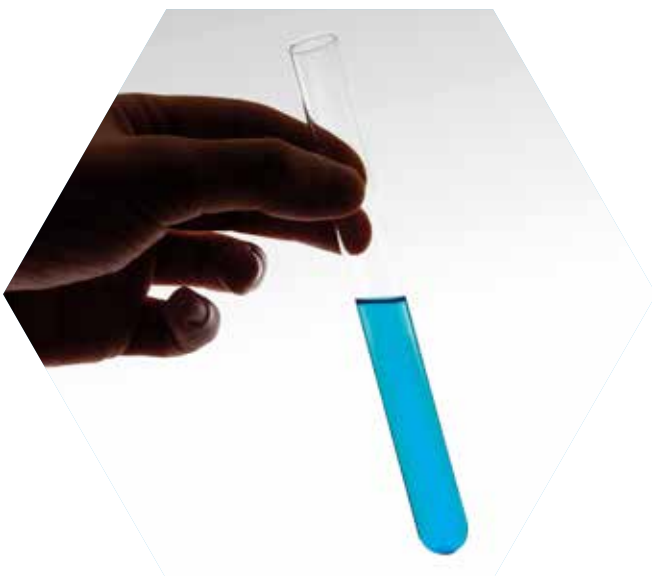

- Robust build
- Aerodynamic front fascia
- Industrial grade electrogalvanised steel construction
- Heavy epoxy powder coated finish to withstand harsh laboratory environments
- Light grey phenolic resin worktop.
- Purpose built light box external to airflow, preventing any corrosion and minimizing turbulence
- Electronic light ballast for flicker free usage and user eye comfort
- Counterbalanced sash assembly for years of trouble free use
- Tempered safety glass with Easygrip® hand rail
- Clear side panels for better visibility
- Stainless steel airfoil designed to maximize air sweep of work surface

Ductless Fume Handling

Fume hoods represent the primary line of defense for personnel from exposure to harmful, toxic and dangerous fumes or chemicals as they are produced.

Advancelab ductless fume hoods have been manufactured to provide the highest levels of safety for laboratory personnel.

Activated carbon filters are suitable for a range of chemicals. Please contact our distributors / offices to help, in doubts selecting a suitable filter.

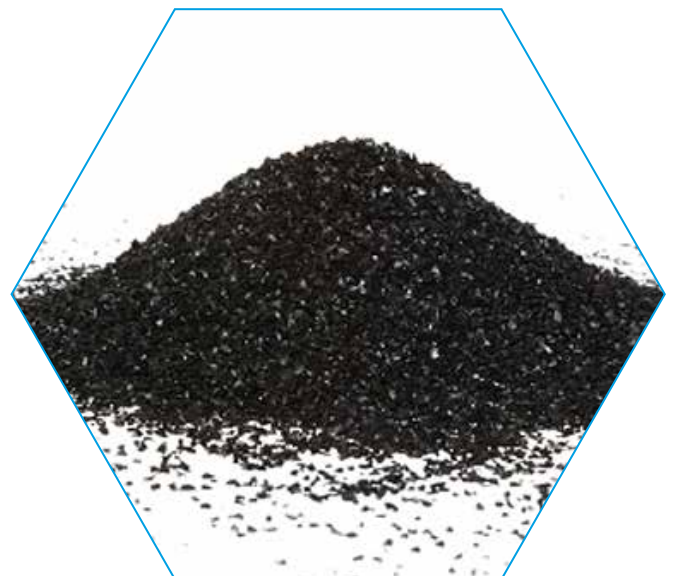

Ductless Fume Hood AD Series

Ductless Fume Hoods

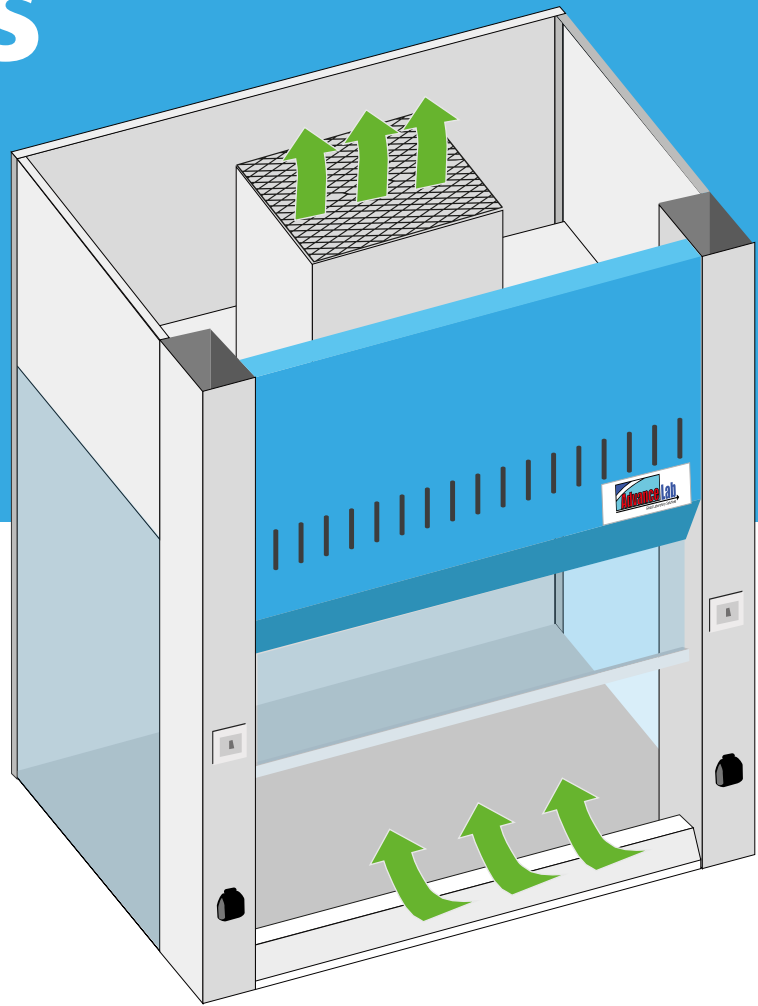

Models

MODEL	AD03FH-DC	AD04FH-DC	AD05FH-DC	AD06FH-DC
Dimensions, mm (LxWxH) Including base cabinet	920mm x 750mm x 2420mm	1220mm x 750mm x 2420mm	1520mm x 750mm x 2420mm	1820mm x 750mm x 2420mm
Body	Electrogalvanised steel with heavy epoxy powder coated finish			
Worktop	Phenolic resin, laboratory grade, light grey			
Airfoil	SS 304			
Standards Complied	ASHRAE 110-95 airflow requirements (0.5m/s +/- 20% as installed)			
Services	2 x Pre wired 13 Amp Switch socket outlets (BS)			
Controls	Fan ON/OFF switch Light ON/OFF switch			
Base (Optional)	Epoxy powder coated steel construction Castor wheels (Optional)			
Design Velocity	0.5 m/s at 500mm sash height			
Extract Volume at 500 mm Height Sash Opening	630 CMH	900 CMH	1170 CMH	1440 CMH

Activated Charcoal Filters

Our high performance filters are responsible for removing chemical fumes before it is recirculated back into the laboratory.

The use of activated carbon filters is dependent on the target chemical, the quantity handled and the frequency of use. General filters have broad retention but may be unsuitable heavy specific usage. Advancelab has a range of standard filters that are more common.



Advancelab CleanAll® Activated Carbon Filters			
MODEL	TYPE	MEDIA TYPE	DESCRIPTION
CF01	General purpose	Extruded activated carbon	VOCs, hydrocarbons, general odours
CF02	Acids	Impregnated activated carbon	Mainly for acids
CF03	Aldehyde	Acid washed granular activated carbon	Mainly for aldehyde & ketones
CF04	Alkalines	Impregnated activated carbon	Mainly for alkalines
HEPA CF05	Particulates or aerosols	H13 HEPA filter	Removes 99.97% particulates $\geq 0.3\mu\text{m}$ (microns)
CF06	Acids	Activated alumina with chemical impregnation	High capacity for acids

Accessories

Advancelab uses high quality fans that ensure airflow is achieved even as the filters are loaded. An optional microprocessor alarm can be installed for low flow warning.

There are 2 aspects to ductless fume hood monitoring:-

- i) Face velocity - this can be measured using hot wire anemometer with 6 grids and multiple readings to reduce standard variation. Velocity is the speed of air entering the hood
- ii) "Filter Saturation"

- "Filter Saturation" measures the loading of the activated carbon filter; whether it has absorbed all the media it can

Gas detection tubes can be used to challenge the filter

- using a suitable gas detection tube

Electronic filter saturation alarms using gas sensors can be

- installed for continues monitoring, this is however recommended for only the most stringent application due to cost consideration



Gas detection tube



Gas sensor alarm

Parts

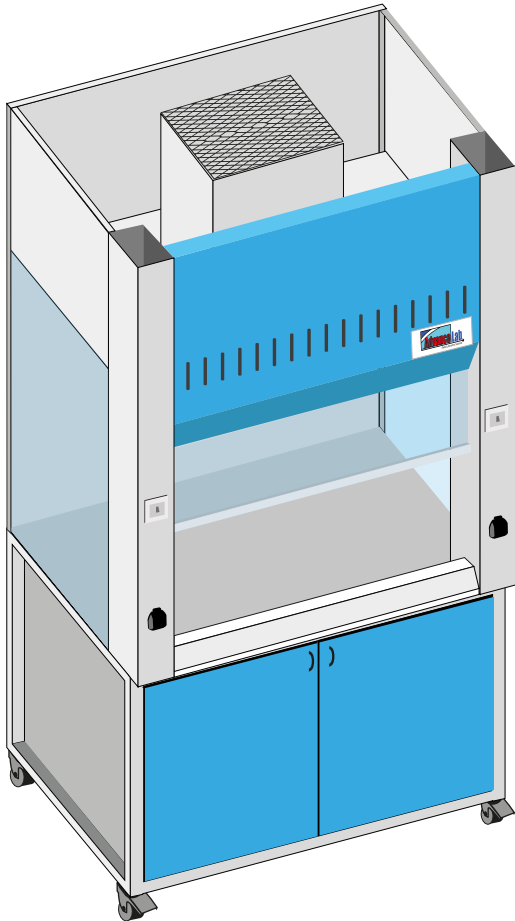

Top View

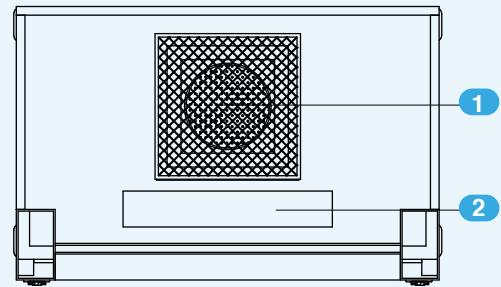

Side View

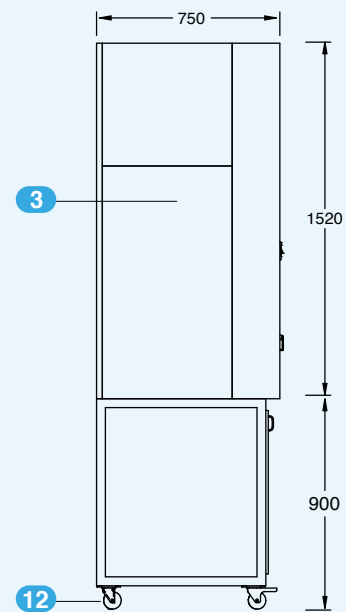

Front View

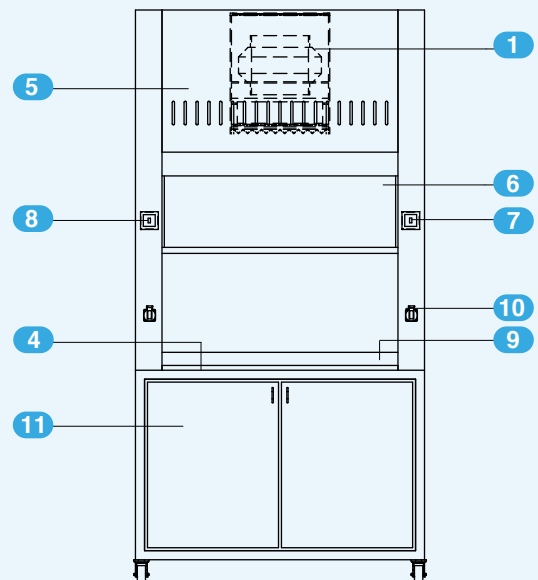

- 1. Activated Carbon Filter & Pre Filter
- 2. External Light Box
- 3. Acrylic Panels (Two Sides)
- 4. Phenolic Worktop
- 5. Fume Hood Front Panel
- 6. Tempered Glass Sash
- 7. Light ON/OFF Switch
- 8. Fan ON/OFF Switch
- 9. Stainless Steel 304 Airfoil
- 10. Electrical Outlets
- 11. Metal Base Cabinet (Optional)
- 12. Castor Wheels (Optional)

Options and Accessories

Superstructure

- Industrial Grade ElectroGalvanised Steel (Standard)
- SS 304
- SS 316
- Polypropylene
- PVDF

Work Top

- Phenolic Resin (Standard)
- Epoxy Resin, USA
- SS 304
- SS 316 L
- Polypropylene
- PVDF

Inner Liner Construction

- Phenolic Resin (Standard)
- SS 304
- SS 316
- Polypropylene
- PVDF

Distillation Grid

- Aluminium
- SS 304
- SS 316

Sink

- Drip Cup
 - Polypropylene (Optional)
- Custom Sink
 - SS 304
 - SS 316
 - Polypropylene (Hot Weld Construction)
 - Size: _____ mm (L x W x H)
please specify



- Location
 - x = mm
 - y = mm

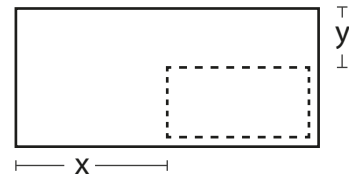

Microprocessor Airflow Alarm

- Digital Display with Alarm



Services

- Compressed Air (CA)
- Distilled Water (DI)
- Nitrogen (N2)
- Oxygen (O2)
- Vacuum (Vac)
- Cold Water

Ex Proof Configurations

- Ex proof lights
- Ex proof on/off switch
- Ex proof Electrical Sockets
- Ex proof electrical junction box

Please advice factory of details required

Electrical Outlet

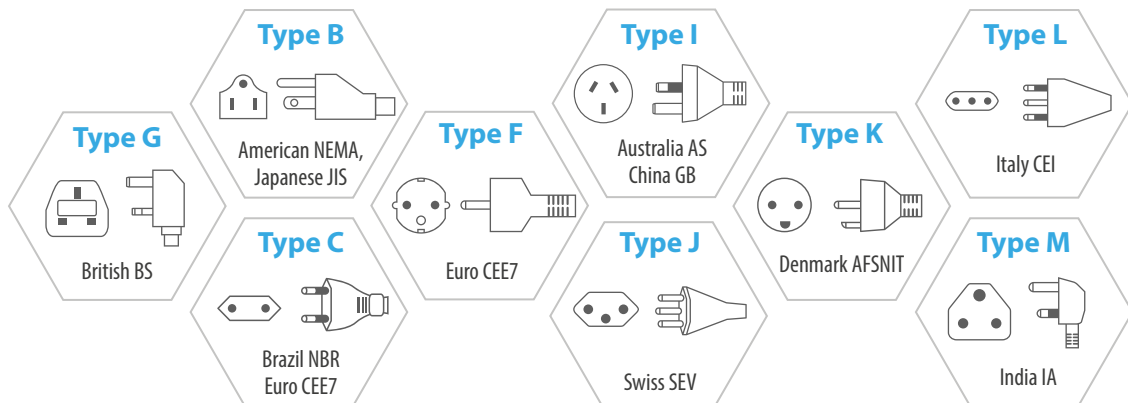

Warranty

Products Manufactured by Advancelab: Advancelab(S) Pte.Ltd., warrants products that it manufactures to be free from defects for a period of 12 months for parts, commencing from the date of shipment. Advancelab's sole responsibility is to repair or replace, at its option, any part of the product that proves defective or malfunctioning during this time limit. This warranty is void if the equipment is abused or modified by the customer, is operated outside Advancelab's operating instructions or specifications, or is used in any application other than that for which it is specified. This warranty does not include routine maintenance or service procedures, breakage, shipping damage, nor damage from misuse, intentional or unintentional abuse, neglect, natural disasters, or acts of God.

Freight Shortage or Damage: Upon receipt of any equipment from Advancelab, customer shall immediately unpack and inspect for damage or shortage. The customer shall not accept a damaged package or a short shipment until the carrier makes a "damage or shortage" notation on both the carrier's and customer's copy of the freight bill or delivery receipt. Service title passes when the shipment is loaded, so customer is responsible for filing and collecting a freight claim. Any replacement products must be ordered and paid for separately.

Generally, customers can improve the chance of collecting on a freight claim by following these procedures:

1. Formally requesting that the carrier inspect the shipment immediately upon suspecting damage or shortage to verify condition.
2. Notifying the carrier upon discovery of concealed damage and requesting an inspection within 15 days of receipt, both in person or phone and following up via mail.
3. Keeping the shipment as intact as possible, including retaining original packaging materials and keeping the product as close to the original receiving location as possible.
4. Holding salvage for disposition by the carrier.

All Claims: Advancelab (S) Pte.Ltd., expressly disclaims all other warranties, expressed or implied or implied by statute, including the warranties of merchantability or fitness for intended use. Advancelab is not responsible for consequential or incidental damages arising out of the purchase or use of the products supplied by Advancelab. Advancelab is not liable for damage to facilities, other equipment, products, property or personnel of others, or of their agents, suppliers, or affiliated parties, which is caused or alleged to have been caused by products supplied by Advancelab. In any event or series of events, Advancelab's total liability for any and all damages whatsoever is limited to the lesser of the actual damages or the original invoice cost of the items alleged to have caused the damage. The customer's sole and exclusive remedy for any cause of action whatsoever is repair or replacement of the non-conforming products or refund of the actual purchase price, at the sole option of Advancelab. All claims must be made in writing within 90 days of the date the product was shipped. Any claims not made within this time limit shall be deemed waived by the customer. Advancelab is not responsible for any additional costs of repair caused by poor packaging or in-shipment damage during return.

Warranty Returns: All warranty returns must be authorized in advance by Advancelab and approved by writing. Unless approved in advance for good reason, all returns must be in original condition, including all manuals, and must be packaged in original packaging materials. All returned goods are to be shipped to Advancelab, freight prepaid at customer's expense.



AdvanceLab has built a rock steady reputation for solutions where most fail. Since our establishment in 2003, we have positioned ourselves as the premier facility solution provider for the scientific industry; designing, building and delivering quickly and without fuss. We have also taken our brand of expertise globally; now with exports of laboratory casework, fume hoods, laminar flow cabinets and clean booths heading to 30 countries, covering all continents.



DESIGNS
FUMES

Indonesia

PT. Advancelab Saintifik

253 Kaki Bukit Ave 1
Singapore 416061
Tel: +65 6448 8255
Fax: +65 6448 9833
Email: info@advancelab.com.sg

Malaysia

Advancelab Sdn Bhd

No. 3388, Jalan Pekeliling Tanjung
27/2, Kawasan Perindustrian Indahpura,
81000 Kulajaya, Johor, Malaysia.
Tel: +607 660 8877
Fax: +607 660 8866
Email: info-my@advancelab-global.com

Myanmar

Advancelab Scientific & Engineering Co., Ltd

No.(81/1)-1A, Myin Thar 7th Street,
(14/1)Ward, South Okkalapa Township,
Yangon, Myanmar
Tel: +95 (9) 779753802
Email: info-mm@advancelab-global.com

Singapore

Advancelab (S) Pte Ltd

253 Kaki Bukit Ave 1
Singapore 416061
Tel: +65 6448 8255
Fax: +65 6448 9833
Email: info@advancelab.com.sg

Thailand

Prima Scientific Co., Ltd

147 / 170 - 171 Baromrajchonnanee
Road, Arunamarin Bangkoknoi,
Bangkok 10700, Thailand.
Tel: +66 2 884 9480
Fax: +66 2 884 6441
Email: primasci@primasci.com

Website:
www.advancelabglobal.com

Indonesia • Malaysia • Myanmar • Philippines • Singapore • Thailand



FUME
HOOD